



Frieling Sanitär-Heizung-Klima



Frieling: Eine Erfolgsgeschichte

Die Frieling Gruppe ist ein Unternehmen, das sich seit seiner Gründung im Jahr 1905 durch solides Wachstum, Kompetenz und Innovation auszeichnet. Ideenreichtum, unternehmerisches Geschick und die soziale Verantwortung zu Arbeitnehmern begründen die stetige positive Entwicklung des Unternehmens.

Neuerungen gegenüber aufgeschlossen zu sein und Visionen anzupacken, das ist unser Leitfaden. In Zeiten von „Geiz ist geil“ atypisch zu handeln und in langfristige Projekte zu investieren, zeichnet die Unternehmenspolitik aus.

Die Vergangenheit als Fundament und das Jetzt und besonders das Morgen immer im Blick, werden wir die Zukunft als einer der führenden Großhändler in dem Bereich Stahlhandel und Stahlanarbeitung, weiter mitgestalten.

Frieling als Ausbildungsbetrieb

Wir bilden in dem Beruf Groß- und Außenhandelskaufmann/-frau aus. Viele Auszubildende haben nach erfolgreich abgeschlossener Prüfung ihren festen Platz im Frieling Team gefunden.

Durch regelmäßige interne Schulungen bereiten wir unsere Auszubildenden gründlich auf ihre Zukunft vor. Mit Hilfe des Rotationsprinzips durch alle Abteilungen hat jeder Auszubildende die Möglichkeit seine Stärken ausfindig zu machen und sie weiter auszubauen.

Team

Unsere Mitarbeiter arbeiten größtenteils im Team, d. h. für den Kunden ist immer ein Ansprechpartner verfügbar. Gezielte Kundenberatung ist unser Schlüssel zum Erfolg. Der persönliche Kontakt zwischen dem Handwerk und unseren Kundenberatern ist unser stärkstes Verkaufsargument. Im intensiven Dialog miteinander arbeiten wir ständig an neuen Konzepten und Ideen, um uns noch effektiver für Sie einzubringen.

Inhaltsverzeichnis

	Seite
Profilstahl	6 - 8
Flachprodukte	10 - 11
Stabstahl	14 - 16
Stahlrohre	18 - 20
Profilrohre	22 - 27
RP-Profile	30 - 32
Spezialprofile	34
nichtrostende Stähle	36 - 39
Aluminium	42 - 44
Pressrosten	46 - 47
Anarbeitung	50



Profilstahl

Breitflanschträger

Formstahl

Gehrungsschnitte

Breitflanschträger

Formstahl und Breitflanschträger

Güte S235 JR nach EN 10025

- schwarz
- ▲ verzinkt
- gestrahlt und gepriment

Abmessung in mm	UNP			IPE		HEA	HEB	HEM
	6 m	12 m	15 m	12 m	15 m	15 m	15 m	15 m
80	▲●	●■		●				
100	▲●	●	■	●	■	●■	▲●■	●
120	▲●	●	■		●■	●■	▲●■	●
140	▲●	●	■		●■	●■	▲●	●
160	▲●	●■			●■	●	▲●	●
180		●■			●■	●	●	●
200		●■			●■	●	●	
220		●			●	●	●	
240		●			●	●	●	
260		●						
270					●			
300		●			●			

Sägen auf Fixlänge

Auf modernsten Sägeeinrichtungen sind Fixlängen mit:

- Normtoleranz von ± 3 mm
- weiter eingengten Toleranzen nach Vereinbarung

bei lagermäßig geführten Profilen möglich.

Profile werden mit rechtwinklig gesägten Enden geliefert.

Gehrungsschnitte

Die auf der folgenden Seite aufgeführten Schnittbilder für Stahlträger und U-Stahl (Toleranzen entsprechend Absprache) führen wir durch.

Basis der Bestellung ist die Angabe des Winkels, gemessen von der Rechtwinkligkeit.

Alle Träger an beiden Enden gesägt.
Längentoleranz nach Absprache.

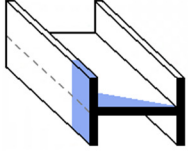
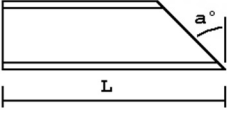
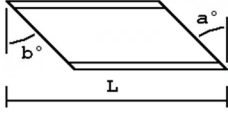
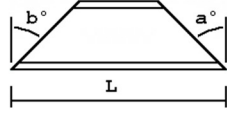
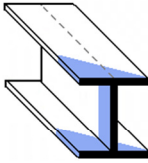
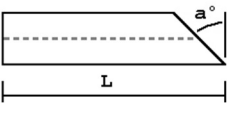
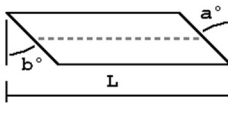
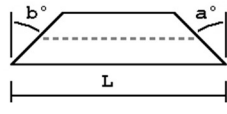
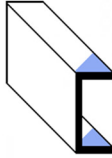
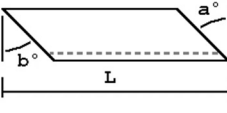
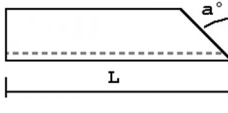
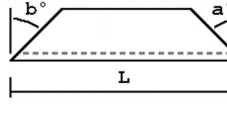
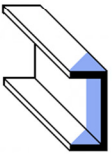
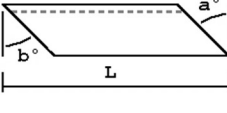
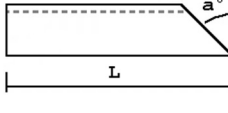
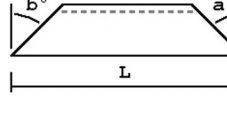
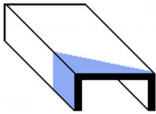
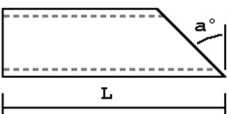
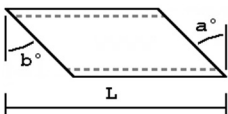
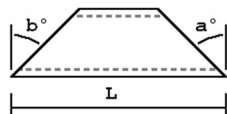
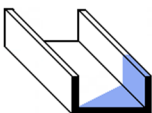
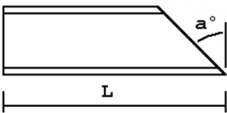
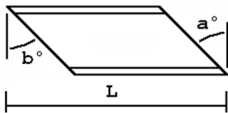
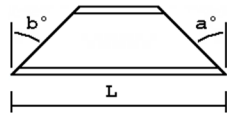
	 Form A	 Form B	 Form C
	 Form D	 Form E	 Form F
	 Form G	 Form N	 Form O
	 Form I	 Form M	 Form P
	 Form H	 Form K	 Form L
	 Form H spiegelbildlich	 Form K spiegelbildlich	 Form L spiegelbildlich

1. Walzstahlkonservierung

Abmessungen

Bleche	Breite max.: 3000 mm Dicke min.: 6 mm Dicke max.: durch Stückgewicht begrenzt
Profile	bis max. HEM 1000 max. Durchgangshöhe der Anlage (Flanschbreite): 350 mm Länge: 2,50 - 18 m (Unter- und Überlängen bedingen erhöhten Aufwand)
Rund- und Profiltröhre	Durchmesser: max. 350 mm Länge: 2,50 - 18 m

Entzunderung

Stahlentzunderung gem. Reinheitsgrad SA 2,5: Zunder, Rost und Beschichtungen werden soweit entfernt, dass lediglich leichte Schattierungen infolge Tönung von Poren sichtbar bleiben.

Primern (Fertigungsbeschichtung):

Konservierung mit 2-Komponenten-Shopprimer "rotbraun" in einer Schichtdicke von 20 +/- 5 µm

Schweißtechnische Eigenschaft: unproblematisch; einwandfreier, glatter Abbrandrand; kein Einfluß auf die Schweißbeignung des Stahl-Grundwerkstoffes.

Universelle Überstreichbarkeit (mit Ausnahme von Beschichtungsstoffen für den direkten Auftrag auf Stahloberflächen, wie z. B. Zinksilikate).

Eine Gewährleistung für den Anstrich bis zum Verbraucher ist ausgeschlossen, da wir keinen Einfluss auf Transport und Lagerung haben.

Andere Abmessungen, Längen, Reinheitsgrade, Beschichtungen und Schichtdicken auf Anfrage.

2. Mechanische Anarbeitung

Nach Vereinbarung lassen wir bei werksfähigen Positionsgrößen folgende Anarbeitungen durchführen:

Bombieren

Über die Y- oder/und Z-Achse für den Hallen- und Brückenbau

- mit Radien > 50 m

Schweißen

Anbringen von Kopf- und Fußplatten, Gurt- und Stegverstärkungen sowie Knotenblechen.

Wabenträger

Herstellung von Wabenträgern nach Peiner Schnittführung mit Profilhöhen von 1,5 x Steghöhe des Grundprofils aus Profilen mit Steghöhen > 200 mm.

Sägen

Die vom Werk gewalzten Profile können zu Längen von 600 - 30000 mm (auf Anfrage länger)

- mit Längentoleranz bis zu +/- 1 mm
- mit Gehrungsschnitten beidseitig bis 45°

gesägt werden.

Bohren

Gebohrt werden Längen von 5000 - 30000 mm (auf Anfrage länger)

- mit Bohrungsdurchmesser von 10 - 50 mm, Durchmesser < 10 und > 50 mm auf Anfrage.



Flachprodukte

Grobbleche

Tränenbleche

Feinbleche

Feinbleche, kaltgewalzt, DC 01

● schwarz

Blechstärke in mm	Blechformat in mm		
	1000 x 2000	1250 x 2500	1500 x 3000
0,63			
0,75	●		
0,88	●		
1,00	●	●	●
1,25	●	●	
1,50	●	●	●
1,75			
2,00	●	●	●
2,25			
2,50	●	●	
2,75			

Feinbleche, DX 51 D+Z, sendzimir verzinkt

▲ verzinkt

Blechstärke in mm	Blechformat in mm		
	1000 x 2000	1250 x 2500	1500 x 3000
0,63	▲		
0,75	▲	▲	
0,88	▲		
1,00	▲	▲	▲
1,25	▲	▲	▲
1,50	▲	▲	▲
1,75			
2,00	▲	▲	▲
2,50			
2,99	▲	▲	▲
4,00		▲	▲

Feinkornbaustahl, S355 MC

● schwarz

◆ gebeizt und gefettet

Blechstärke in mm	Blechformat in mm		
	1250 x 2500	1500 x 3000	2000 x 4000
3,0	●	● ◆	
4,0	●	● ◆	
5,0	●	● ◆	
6,0	●	● ◆	●
8,0	●	● ◆	●
10,0		● ◆	●
12,0		● ◆	
15,0		● ◆	
20,0		● ◆	

Bleche, warmgewalzt, S235 JR

- schwarz
- ◆ gebeizt und gefettet

Blechstärke in mm	Blechformat in mm		
	1000 x 2000	1250 x 2500	1500 x 3000
3,0	●	●	● ◆
4,0	●	●	● ◆
5,0	●	●	● ◆
6,0	●	●	● ◆
8,0	●	●	● ◆
10,0	●	●	● ◆
12,0	●	●	● ◆
15,0	●	●	● ◆
20,0	●	●	● ◆

	2000 x 6000
3,0	●
4,0	●
8,0	●
10,0	●
12,0	●
15,0	●
20,0	●
25,0	●
30,0	●
35,0	●
40,0	●
50,0	●

Tränenbleche, S235 JR

- schwarz

Blechstärke in mm	Blechformat in mm		
	1000 x 2000	1250 x 2500	1500 x 3000
3,0		●	●
4,0	●	●	●
5,0	●	●	
6,0	●	●	
8,0	●	●	
10,0	●	●	

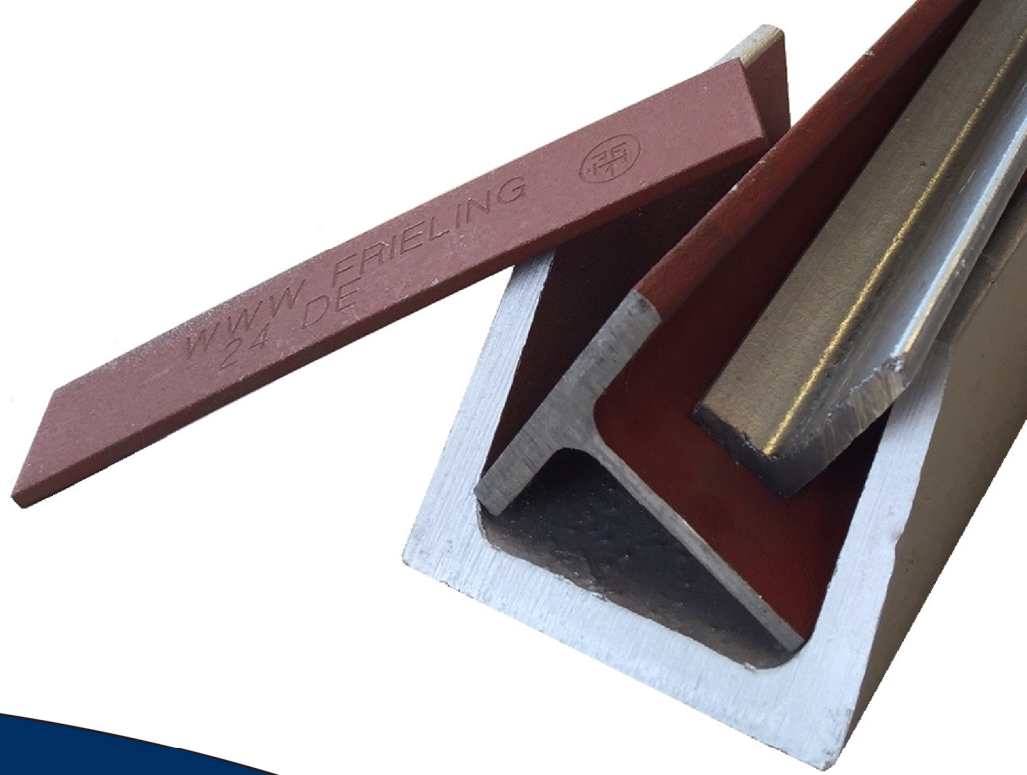

Stabstahl

Flach- und Bandstahl

Winkelstahl

Rund- und Vierkantstahl

T- und U-Stahl

blanker Rundstahl

Stabstahl

Flach- und Breitflachstahl, EN 10058, S235 JR

Handelslänge ca. 6 m

- schwarz
- ▲ verzinkt

Abmessung in mm	5	6	8	10	12	15	20	25	30
10	●								
12	●								
16	●	●	●	●					
20	●▲	●	●	●	●	●			
25	●▲	●	●	●	●	●			
30	●▲	●▲	●	●	●	●	●		
35	●	●	●	●	●				
40	●▲	●▲	●▲	●▲	●	●	●▲		
45	●	●	●	●	●	●			
50	●▲	●▲	●▲	●▲	●	●	●		●
60	●▲	●▲	●▲	●▲	●	●	●		
65				●					
70	●	●	●	●	●	●	●		
75				●					
80	●▲	●	●▲	●▲	●	●	●		●
90			●	●	●	●			
100	●▲	●	●▲	●▲	●	●	●		
110		●		●					
120			●	●▲	●	●	●		
130			●	●	●	●	●		
140			●	●	●	●	●		
150			●	●	●	●	●		
160			●	●	●	●	●		
180			●	●	●	●	●		
200			●	●	●	●	●		
250				●	●	●	●		
300				●					

Bandstahl in Stäben, EN 10048, S235 JR

Handelslänge ca. 6 m

Abmessung in mm	2	3	4	5	6
20		●	●		
25		●	●		
30		●	●		
40		●	●		
50		●	●		
80		●			
100		●			
110					●
120				●	●
150				●	●

Winkelstahl, EN 10056, S235 JR

Handelslänge ca. 6 m

- schwarz
- ▲ verzinkt
- gestrahlt und geprimert

Abmessung in mm	3	4	5	6	7	8	9	10	11
20 x 20	●▲								
25 x 25	●▲	●							
30 x 30	●▲	●	●						
35 x 35		●▲	●						
40 x 40		●▲	●	●					
45 x 45			●	●					
50 x 50			●▲■	●					
60 x 60			▲	●▲		●			
70 x 70					●▲				
75 x 75						●			
80 x 80						●▲		●	
100 x 100						●▲		●▲	
120 x 120									●▲
40 x 20	●	●▲							
50 x 30			●						
50 x 40			▲						
60 x 30			●▲						
60 x 40			●▲						
75 x 50			●			■			
80 x 40				●▲					
90 x 60				●					
100 x 50				●▲		●▲			
100 x 65					▲				
100 x 75							▲		
120 x 80						●▲		■	
130 x 65						●			
150 x 75							●■		
150 x 100								▲	
180 x 90								■	
200 x 100								●■	

Rund- und Vierkantstahl, EN 10060 bzw. EN 10059, S235 JR

Handelslänge ca. 6 m

Abmessung in mm	Rundstahl	Vierkantstahl
6	●▲	●
8	●▲	●
10	●▲	●
12	●▲	●
14	●▲	●
15	●	●
16	●▲	●
18	●	●
20	●	●
22	●	●
24	●	
25	●	●
28	●	
30	●	●
35		●
40	●	

T-Stahl, DIN EN 10055, S235 JR

hochstegig, rundkantig
Handelslänge ca. 6 m

● schwarz
▲ verzinkt

Abmessung in mm	schwarz	verzinkt
25 x 25 x 3,5	●	
30 x 30 x 4	●	
35 x 35 x 4,5	●	
40 x 40 x 5	●	▲
45 x 45 x 5,5	●	
50 x 50 x 6	●	▲
60 x 60 x 7	●	
70 x 70 x 8	●	
80 x 80 x 9	●	
100 x 100 x 11	●	

U-Stahl, EN 10279, S235 JR

Handelslänge ca. 6 m

Abmessung in mm	schwarz	verzinkt
30 x 15 x 4	●	
30 x 33 x 5	●	
40 x 20 x 5	●	
40 x 35 x 5	●	▲
50 x 25 x 5	●	
50 x 38 x 5	●	▲
60 x 30 x 6	●	
65 x 42 x 6	●	▲

Blankgezogener Rundstahl

Handelslänge ca. 6 m

Abmessung in mm	S355J2 C+C / SH
6	●
8	●
10	●
12	●
15	●
16	●
18	●
19	●
20	●
22	●
25	●
28	●
30	●
35	●
40	●
45	●
50	●
60	●
70	●



Stahlrohre

Gewinderohre

FF-Rohre

Hydraulikleitungsrohre

Konstruktionsrohre

Rundrohre, nahtlos

Rundrohre, geschweißt

Gewichtsliste

Rundrohre

Gewinderohre EN 10255-M, S195-T

Handelslängen ca. 6 m

- schwarz, Handelslänge ca. 6 m
- ▲ verzinkt, Handelslänge ca. 6 m

Durchmesser in mm	Wandstärke in mm												
	2,3		2,6		3,2		3,6		4,0		4,5		
	geschw.	nahtlos	geschw.	nahtlos	geschw.	nahtlos	geschw.	nahtlos	geschw.	nahtlos	geschw.	nahtlos	
1/4"	●												
3/8"	●▲	●▲											
1/2"			●▲	●▲									
3/4"			●▲	●▲									
1"					●▲	●▲							
1 1/4"					●▲	●▲							
1 1/2"					●▲	●▲							
2"							●▲	●▲					
2 1/2"							▲	▲					
3"									▲	▲			
4"											▲		

geschweißte FF-Rohre, streckreduziert

Handelslängen ca. 6 m

- schwarz, Handelslänge ca. 6 m
- ▲ verzinkt, Handelslänge ca. 6 m

Durchmesser in mm	Wandstärke in mm					
	2,0	2,6	2,9	3,2	3,2	3,6
1/2"		●▲				
3/4"		●▲				
1"					●▲	
1 1/4"					●▲	
1 1/2"					●▲	
2"						●▲

Gewinderohre EN 10255-M, S195-T

Handelslängen ca. 6 m

- schwarz, Handelslänge ca. 6 m
- bandgeschweißt

Durchmesser in mm	Wandstärke in mm				
	2,6	3,2	3,6	4,0	4,5
1/2"	●				
3/4"	●				
1"		●			
1 1/4"		●			
1 1/2"		●			
2"			●		
3"				●	
4"					●

Konstruktionsrohre DIN 2458/1615

- schwarz, Handelslänge ca. 6 m geschweißt

Durchmesser in mm	Wandstärke in mm	
	2,00	2,50
1/2"	●	
3/4"	●	
1"		●
1 1/4"		●
1 1/2"		●
2"		●

Hydraulikleitungsrohre EN 10305-4

nahtl., wirbelstromgeprüft, galv. verzinkt, Cr-6 frei

- ▲ verzinkt, Handelslänge ca. 6 m

Durchmesser in mm	Wandstärke in mm		
	1,00	1,50	2,00
8,0	▲		
10,0	▲		
12,0		▲	
15,0		▲	
18,0		▲	
22,0			▲

Rundrohre

- nahtlos EN 10216-1, P235 TR 1
- ◆ geschweißt EN 10217-1, P235 TR 1 / EN 10219, S235JRH
- ▲ nachträglich feuerverzinkt nach DIN ISO 1461

Durchmesser in mm	Wandstärke in mm													
	1,8	2,0	2,3	2,3	2,6	2,9	3,2	3,6	4,0	4,5	5,0	5,6	6,3	7,1
13,5														
16,0														
17,2														
20,0														
21,3														
25,0														
26,9														
30,0					◆▲									
31,8														
33,7														
38,0					●									
42,4					●									
44,5					●									
48,3					●									
51,0					●									
57,0						●								
60,3						●								
63,5						●								
70,0						●								
76,1						●◆								
82,5							●							
88,9		◆▲					●◆		◆					
101,6								●						
108,0						◆▲		●						
114,3								●						
121,0									●					
127,0									●					
133,0									●					
139,7									●					
152,4														
159,0						◆				●				
165,1														
168,3										●				
177,8														
193,7														
219,1										◆			●	
244,5														

unverbindliche Gewichtsliste

Gewinderohre, EN 10255-M, mit glatten Enden

Nennweite in Zoll	1/8	1/4	3/8	1/2	3/4	1	1 1/4	1 1/2	2	2 1/2	3	4	5	6
Äußer. Durchm., mm	10,2	13,5	17,2	21,3	26,9	33,7	42,4	48,3	60,3	76,1	88,9	114,3	139,7	165,1
Wandstärke mm	2,0	2,3	2,3	2,6	2,6	3,2	3,2	3,2	3,6	3,6	4,0	4,5	4,8	4,8
schwarz, kg / m	0,407	0,650	0,852	1,22	1,58	2,44	3,14	3,61	5,10	6,51	8,47	12,10	12,20	19,20
verzinkt, kg / m	—	0,679	0,890	1,27	1,65	2,55	3,28	3,77	5,33	6,80	8,85	12,67	16,93	20,06

Gewinderohre, EN 10255-M, mit Gewinde und Muffen

Nennweite in Zoll	1/8	1/4	3/8	1/2	3/4	1	1 1/4	1 1/2	2	2 1/2	3	4	5	6
Äußer. Durchm., mm	10,2	13,5	17,2	21,3	26,9	33,7	42,4	48,3	60,3	76,1	88,9	114,3	139,7	165,1
Wandstärke mm	2,0	2,3	2,3	2,6	2,6	3,2	3,2	3,2	3,6	3,6	4,0	4,5	4,8	4,8
schwarz, kg / m	0,410	0,654	0,850	1,23	1,59	2,46	3,17	3,65	5,17	6,63	8,64	12,40	16,70	19,80
verzinkt, kg / m	—	0,683	0,897	1,29	1,66	2,57	3,31	3,81	5,40	6,93	9,03	12,96	17,37	20,59

Gewinderohre, EN 10255-H, mit glatten Enden

Nennweite in Zoll	1/8	1/4	3/8	1/2	3/4	1	1 1/4	1 1/2	2	2 1/2	3	4	5	6
Äußer. Durchm., mm	10,2	13,5	17,2	21,3	26,9	33,7	42,4	48,3	60,3	76,1	88,9	114,3	139,7	165,1
Wandstärke mm	2,6	2,9	2,9	3,2	3,2	4,0	4,0	4,0	4,5	4,5	4,8	5,4	5,4	5,4
schwarz, kg / m	0,493	0,769	1,02	1,45	1,90	2,97	3,84	4,43	6,17	7,90	10,10	14,40	17,80	21,20
verzinkt, kg / m	—	0,804	1,07	1,52	1,99	3,10	4,01	4,63	6,45	8,26	10,55	15,05	18,60	22,15

Gewinderohre, EN 10255-H, mit Gewinde und Muffen

Nennweite in Zoll	1/8	1/4	3/8	1/2	3/4	1	1 1/4	1 1/2	2	2 1/2	3	4	5	6
Äußer. Durchm., mm	10,2	13,5	17,2	21,3	26,9	33,7	42,4	48,3	60,3	76,1	88,9	114,3	139,7	165,1
Wandstärke mm	2,6	2,9	2,9	3,2	3,2	4,0	4,0	4,0	4,5	4,5	4,8	5,4	5,4	5,4
schwarz, kg / m	0,496	0,773	1,03	1,46	1,91	2,99	3,87	4,47	6,24	8,02	10,30	14,70	18,30	21,80
verzinkt, kg / m	—	0,808	1,08	1,53	2,00	3,12	4,04	4,67	6,52	8,38	10,76	15,36	19,03	22,67



Profilrohre

Profilrohre quadratisch

Profilrohre rechteckig

Stahlbauhohlprofile

Profilrohre

geschweißte Profilrohre EN 10305-5 / 10219

- schwarz, Handelslänge ca. 6 m
- ▲ verzinkt, Handelslänge ca. 6 m

Abmessung in mm	Wandstärke in mm					
	1,5	2	3	4	5	8
15 x 15	●					
20 x 20	●	● ▲				
25 x 25		● ▲				
30 x 30	●	● ▲	● ▲			
34 x 34		● ▲				
35 x 35		●				
40 x 40		● ▲	● ▲	● ▲		
45 x 45		●				
50 x 50		● ▲	●	● ▲	●	
60 x 60		● ▲	●	●	●	
70 x 70			●	●		
80 x 80			● ▲	●	●	●
90 x 90			●	●		
100 x 100			● ▲	●	●	
120 x 120				●		

Abmessung in mm	Wandstärke in mm					
	1,5	2	3	4	5	8
30 x 10	●					
30 x 15		●				
30 x 20		● ▲				
34 x 20		●				
35 x 20		●				
40 x 10	●					
40 x 20		● ▲	●			
40 x 25		●				
40 x 30		● ▲	●			
50 x 20		● ▲				
50 x 30		● ▲	●			
50 x 40		●				
55 x 34		● ▲				
60 x 20		● ▲				
60 x 30		● ▲	●			
60 x 40		● ▲	●	●		
60 x 50			●			
70 x 30			●			
70 x 50				●		
80 x 40		● ▲	● ▲	●	●	
80 x 60			●	●	●	
100 x 40			●			
100 x 50			● ▲	●		
100 x 60			●			
100 x 80			●			
120 x 60			●	●		
120 x 80			●	●		
140 x 80				●		

Hohlprofile nach EN 10219/1+2 / EN 10210, HL 6 m bzw. 12 - 15 m

S235JRH, S275J0H, Werkszeugnis EN 10204 / 2.2,

S355J2H, Werkszeugnis EN 10204 / 3.1 B

Abmessung	kg/m	Kategorie
40 x 40 x 2,9	<i>3,31</i>	w
3	<i>3,30</i>	k
4	<i>4,20</i>	k w
5	<i>4,99</i>	k w
50 x 50 x 2,9	<i>4,22</i>	w
3	<i>4,25</i>	k
4	<i>5,64</i>	k w
5	<i>6,85</i>	k w
6	<i>7,56</i>	k
6,3	<i>8,31</i>	w
8	<i>10,00</i>	w
60 x 60 x 2,9	<i>5,13</i>	w
3	<i>5,19</i>	k
4	<i>6,71</i>	k w
5	<i>8,42</i>	k w
6	<i>9,45</i>	k
6,3	<i>10,30</i>	w
8	<i>12,50</i>	k w
70 x 70 x 3	<i>6,13</i>	k w
3,2	<i>6,63</i>	w
4	<i>8,15</i>	k w
4,5	<i>9,08</i>	w
5	<i>9,99</i>	k w
5,6	<i>11,10</i>	w
6	<i>11,30</i>	k
6,3	<i>12,30</i>	w
7,1	<i>13,60</i>	w
8	<i>15,00</i>	k w
10	<i>18,00</i>	w
80 x 80 x 3	<i>7,07</i>	k
3,6	<i>8,53</i>	k w
4	<i>9,22</i>	k w
4,5	<i>10,50</i>	k w
5	<i>11,60</i>	k w
5,6	<i>12,80</i>	k w
6	<i>13,20</i>	k
6,3	<i>13,50</i>	k w
7,1	<i>15,80</i>	k w
8	<i>17,50</i>	k w
8,8	<i>19,00</i>	w
10	<i>21,10</i>	w
12	<i>25,20</i>	w

Abmessung	kg/m	Kategorie
90 x 90 x 3	<i>8,01</i>	k
3,6	<i>9,66</i>	w
4	<i>10,70</i>	k w
4,5	<i>11,90</i>	w
5	<i>13,10</i>	k w
5,6	<i>14,60</i>	w
6	<i>15,10</i>	k
6,3	<i>15,50</i>	k w
7,1	<i>18,10</i>	w
8	<i>20,10</i>	k w
8,8	<i>21,80</i>	w
10	<i>24,30</i>	w
12,5	<i>29,10</i>	w
100 x 100 x 3	<i>8,96</i>	k
4	<i>11,90</i>	k w
5	<i>14,70</i>	k w
5,6	<i>16,30</i>	w
6	<i>17,00</i>	k w
6,3	<i>18,20</i>	k w
8	<i>22,60</i>	k w
10	<i>27,40</i>	k w
12,5	<i>33,00</i>	w
110 x 110 x 4	<i>13,20</i>	k w
5	<i>16,30</i>	k w
6	<i>18,87</i>	k
6,3	<i>20,20</i>	w
8	<i>25,10</i>	k w
10	<i>30,60</i>	k w
120 x 120 x 3	<i>10,80</i>	k
4	<i>14,40</i>	k w
4,5	<i>16,10</i>	w
5	<i>17,80</i>	k w
5,6	<i>19,90</i>	k w
6	<i>20,70</i>	k
6,3	<i>22,20</i>	k w
7,1	<i>24,70</i>	w
8	<i>27,60</i>	k w
8,8	<i>30,10</i>	w
10	<i>33,70</i>	k w
12,5	<i>40,90</i>	k w
125 x 125 x 5	<i>18,33</i>	k
6	<i>21,69</i>	k

Stahlbauhohlprofile

Abmessung	kg/m	Kategorie
140 x 140 x 3	<i>12,70</i>	k
4	<i>16,80</i>	k
5	<i>21,00</i>	k w
5,6	<i>23,40</i>	w
6	<i>24,50</i>	k
6,3	<i>26,10</i>	k w
7,1	<i>29,20</i>	k w
8	<i>32,60</i>	k w
8,8	<i>35,60</i>	w
10	<i>38,10</i>	k w
12,5	<i>48,70</i>	w
16	<i>60,10</i>	w
150 x 150 x 3	<i>13,70</i>	k
4	<i>18,00</i>	k
5	<i>22,30</i>	k w
6	<i>26,40</i>	k
6,3	<i>27,40</i>	k w
8	<i>35,10</i>	k w
10	<i>43,10</i>	k w
12,5	<i>52,70</i>	k w
16	<i>65,20</i>	w
160 x 160 x 4	<i>19,30</i>	k
5	<i>23,80</i>	k
6	<i>28,30</i>	k
6,3	<i>30,10</i>	k w
8	<i>37,60</i>	k w
10	<i>46,30</i>	k w
12,5	<i>56,60</i>	k w
14,2	<i>63,30</i>	w
16	<i>70,20</i>	w
180 x 180 x 5	<i>27,00</i>	k
6	<i>32,10</i>	k
6,3	<i>34,00</i>	k w
8	<i>42,70</i>	k w
8,8	<i>46,70</i>	w
10	<i>52,50</i>	k w
12,5	<i>60,50</i>	k w
14,2	<i>72,20</i>	w
16	<i>80,20</i>	w
200 x 200 x 4	<i>24,30</i>	k
5	<i>30,10</i>	k
6	<i>35,80</i>	k
6,3	<i>38,00</i>	k w
7,1	<i>42,60</i>	w
8	<i>47,70</i>	k w
10	<i>58,80</i>	k w
12,5	<i>72,30</i>	k w
14,2	<i>81,10</i>	w
16	<i>90,30</i>	w
220 x 220 x 6	<i>39,60</i>	k
6,3	<i>41,90</i>	k w
8	<i>52,70</i>	k w
10	<i>65,10</i>	k w
12,5	<i>80,10</i>	k w
14,2	<i>90,10</i>	w
16	<i>100,00</i>	w

Abmessung	kg/m	Kategorie
250 x 250 x 6	<i>45,20</i>	k
6,3	<i>47,10</i>	k w
8	<i>60,30</i>	k w
10	<i>74,50</i>	k w
12,5	<i>91,90</i>	k w
16	<i>115,00</i>	w
260 x 260 x 6	<i>47,10</i>	k
7,1	<i>56,00</i>	k w
8	<i>62,80</i>	k w
8,8	<i>68,80</i>	k w
10	<i>75,80</i>	k w
11	<i>85,00</i>	k w
12,5	<i>95,80</i>	k w
14,2	<i>108,00</i>	w
16	<i>120,00</i>	w
17,5	<i>131,00</i>	w
300 x 300 x 5	<i>45,58</i>	k
6	<i>54,70</i>	k
8	<i>72,80</i>	k w
10	<i>90,20</i>	k w
12,5	<i>112,00</i>	k w
16	<i>141,00</i>	k w
350 x 350 x 8	<i>85,40</i>	w
10	<i>106,00</i>	w
12,5	<i>131,00</i>	k w
16	<i>166,00</i>	w
400 x 400 x 8	<i>97,90</i>	k w
10	<i>122,00</i>	k w
12,5	<i>151,00</i>	k w
16	<i>191,00</i>	k w
40 x 20 x 2	<i>1,68</i>	k
3	<i>2,41</i>	k
40 x 30 x 2	<i>2,07</i>	k
3	<i>2,87</i>	k
50 x 30 x 2	<i>2,31</i>	k
2,9	<i>3,31</i>	w
3	<i>3,30</i>	k
4	<i>4,39</i>	k w
5	<i>5,18</i>	w
60 x 30 x 2	<i>2,69</i>	k
3	<i>3,80</i>	k
4	<i>4,83</i>	k
60 x 40 x 2	<i>2,93</i>	k
2,9	<i>4,22</i>	w
3	<i>4,25</i>	k
4	<i>5,64</i>	k w
5	<i>6,85</i>	k w
6	<i>7,56</i>	k
6,3	<i>8,31</i>	w
8	<i>10,00</i>	w
70 x 40 x 2	<i>3,25</i>	k
2,9	<i>4,67</i>	w
3	<i>4,72</i>	k
4	<i>6,27</i>	k w
5	<i>7,34</i>	k w
6,3	<i>9,30</i>	w

Abmessung	kg/m	Kategorie
70 x 50 x 3	<i>5,19</i>	k
80 x 40 x 2	<i>3,56</i>	k
2,9	<i>5,13</i>	w
3	<i>5,19</i>	k
4	<i>6,90</i>	k w
4,5	<i>7,67</i>	w
5	<i>8,42</i>	k w
6	<i>9,45</i>	k
6,3	<i>10,30</i>	w
8	<i>12,50</i>	w
80 x 50 x 2	<i>3,88</i>	k
3	<i>5,69</i>	k
4	<i>7,34</i>	k
5	<i>8,91</i>	k
80 x 60 x 2	<i>4,26</i>	k
3	<i>6,13</i>	k
4	<i>7,97</i>	k
5	<i>9,70</i>	k
6	<i>11,33</i>	k
8	<i>15,60</i>	w
90 x 50 x 3	<i>6,13</i>	k
3,2	<i>6,63</i>	w
4	<i>8,15</i>	k w
5	<i>9,99</i>	k w
6,3	<i>12,30</i>	w
7,1	<i>13,60</i>	w
8	<i>15,00</i>	w
10	<i>18,00</i>	w
100 x 40 x 3	<i>6,13</i>	k
4	<i>7,97</i>	k
5	<i>9,70</i>	k
100 x 50 x 3	<i>6,60</i>	k
3,6	<i>7,96</i>	w
4	<i>8,78</i>	k w
4,5	<i>9,79</i>	w
5	<i>10,80</i>	k w
5,6	<i>11,90</i>	w
6	<i>12,30</i>	k
6,3	<i>13,30</i>	w
7,1	<i>14,70</i>	w
8	<i>16,30</i>	k w
10	<i>19,60</i>	w
100 x 60 x 3	<i>7,07</i>	k
3,6	<i>8,53</i>	w
4	<i>9,41</i>	k w
4,5	<i>10,50</i>	w
5	<i>11,30</i>	k w
5,6	<i>12,80</i>	k w
6	<i>13,20</i>	k
6,3	<i>14,20</i>	k w
7,1	<i>15,80</i>	k w
8	<i>17,50</i>	k w
8,8	<i>19,00</i>	w
10	<i>21,10</i>	w

Abmessung	kg/m	Kategorie
100 x 80 x 3	<i>8,01</i>	k
4	<i>10,50</i>	k
5	<i>12,80</i>	k
6	<i>15,10</i>	k
8	<i>18,87</i>	k
110 x 60 x 3,6	<i>9,09</i>	w
4	<i>9,85</i>	k
4,5	<i>11,20</i>	w
5,6	<i>13,70</i>	k
6,3	<i>15,20</i>	w
120 x 40 x 3	<i>7,10</i>	k
4	<i>9,22</i>	k
5	<i>11,30</i>	k
120 x 50 x 3	<i>7,54</i>	k
4	<i>9,85</i>	k
5	<i>12,10</i>	k
120 x 60 x 3	<i>8,01</i>	k
4	<i>10,70</i>	k w
5	<i>13,10</i>	k w
5,6	<i>14,60</i>	w
6	<i>15,10</i>	k
6,3	<i>16,20</i>	k w
7,1	<i>18,10</i>	k w
8	<i>20,10</i>	k w
8,8	<i>21,80</i>	w
10	<i>24,30</i>	w
120 x 80 x 3	<i>8,96</i>	k
4	<i>11,90</i>	k w
5	<i>14,70</i>	k w
6	<i>17,00</i>	k
6,3	<i>18,20</i>	w
7,1	<i>20,30</i>	w
8	<i>22,60</i>	k w
8,8	<i>24,50</i>	w
10	<i>27,40</i>	k w
12,5	<i>33,00</i>	w
120 x 100 x 4	<i>14,99</i>	k
5	<i>15,89</i>	k
6	<i>18,87</i>	k
8	<i>23,90</i>	k
140 x 40 x 3	<i>8,01</i>	k
4	<i>10,50</i>	k
5	<i>12,80</i>	k
140 x 60 x 3	<i>8,96</i>	k
4	<i>11,70</i>	k
5	<i>14,40</i>	k
6	<i>17,00</i>	k
8	<i>21,39</i>	k
140 x 70 x 3	<i>9,43</i>	k
4	<i>12,60</i>	k w
5	<i>15,50</i>	k w
6	<i>17,92</i>	k
6,3	<i>19,20</i>	w

Stahlbauhohlprofile

Abmessung	kg/m	Kategorie
140 x 70 x 7,1	<i>21,40</i>	w
8	<i>23,80</i>	k w
8,8	<i>25,90</i>	k w
10	<i>29,00</i>	k w
12,5	<i>35,00</i>	w
140 x 80 x 3	<i>9,90</i>	k
4	<i>13,20</i>	k w
5	<i>16,30</i>	k w
5,6	<i>18,10</i>	w
6	<i>18,90</i>	k
6,3	<i>20,20</i>	w
7,1	<i>22,50</i>	w
8	<i>25,10</i>	k w
10	<i>30,60</i>	k w
12,5	<i>37,00</i>	w
140 x 100 x 4	<i>14,30</i>	k
5	<i>17,55</i>	k
6	<i>20,75</i>	k
150 x 40 x 4	<i>11,50</i>	k
150 x 50 x 3	<i>8,96</i>	k
4	<i>11,70</i>	k
5	<i>14,40</i>	k
150 x 75 x 5	<i>16,37</i>	k
6	<i>19,34</i>	k
150 x 100 x 4	<i>14,90</i>	k
5	<i>18,60</i>	k w
6	<i>21,70</i>	k
6,3	<i>22,40</i>	k w
8	<i>28,90</i>	k w
10	<i>35,30</i>	k w
12,5	<i>42,80</i>	w
160 x 80 x 3	<i>10,77</i>	k
4	<i>14,40</i>	k w
5	<i>17,80</i>	k w
6	<i>20,70</i>	k
6,3	<i>22,20</i>	k w
8	<i>27,60</i>	k w
10	<i>33,70</i>	k w
12,5	<i>40,90</i>	w
160 x 90 x 4	<i>15,10</i>	k
4,5	<i>16,90</i>	w
5	<i>18,33</i>	k
5,6	<i>20,70</i>	w
6	<i>21,69</i>	k
6,3	<i>23,10</i>	k w
7,1	<i>25,90</i>	k w
8	<i>28,90</i>	k w
8,8	<i>31,50</i>	w
10	<i>35,30</i>	k w
12,5	<i>42,80</i>	w
180 x 60 x 3	<i>10,80</i>	k
180 x 80 x 4	<i>15,40</i>	k
5	<i>19,12</i>	k
6	<i>22,63</i>	k
8	<i>28,92</i>	k
180 x 100 x 4	<i>16,80</i>	k

Abmessung	kg/m	Kategorie
180 x 100 x 5	<i>20,70</i>	k
5,6	<i>23,40</i>	w
6	<i>24,50</i>	k
6,3	<i>26,10</i>	k w
7,1	<i>29,20</i>	k w
8	<i>32,60</i>	k w
8,8	<i>35,60</i>	w
10	<i>40,00</i>	k w
12,5	<i>48,70</i>	w
16	<i>60,10</i>	w
180 x 120 x 4	<i>18,00</i>	k
5	<i>22,30</i>	k
6	<i>26,40</i>	k
8	<i>28,92</i>	k
200 x 40 x 3	<i>10,80</i>	k
4	<i>14,40</i>	k
5	<i>17,55</i>	k
200 x 80 x 3	<i>12,70</i>	k
4	<i>16,80</i>	k
5	<i>20,70</i>	k
6	<i>24,52</i>	k
8	<i>31,43</i>	k
200 x 100 x 4	<i>18,00</i>	k
5	<i>22,30</i>	k
6	<i>26,40</i>	k
6,3	<i>28,10</i>	k w
8	<i>35,10</i>	k w
10	<i>43,10</i>	k w
12,5	<i>52,70</i>	k w
16	<i>65,20</i>	w
200 x 120 x 4	<i>19,30</i>	k
5	<i>23,80</i>	k
6	<i>28,30</i>	k
6,3	<i>30,10</i>	k w
8	<i>37,60</i>	k w
10	<i>46,30</i>	k w
12,5	<i>56,60</i>	k w
14,2	<i>63,30</i>	w
16	<i>70,20</i>	w
200 x 150 x 4	<i>21,20</i>	k
5	<i>26,18</i>	k
6	<i>31,11</i>	k
8	<i>40,23</i>	k
10	<i>49,11</i>	k
220 x 120 x 6	<i>30,17</i>	k
6,3	<i>32,00</i>	k w
8	<i>40,20</i>	k w
10	<i>49,40</i>	k w
12,5	<i>60,50</i>	w
14,2	<i>67,80</i>	w
16	<i>75,20</i>	w
250 x 100 x 4	<i>21,20</i>	k
5	<i>26,06</i>	k
6	<i>31,10</i>	k
8	<i>40,27</i>	k
10	<i>49,38</i>	k

Abmessung	kg/m	Kategorie
250 x 150 x 5	<i>30,10</i>	k
6	<i>35,80</i>	k
6,3	<i>38,00</i>	w
8	<i>47,70</i>	k w
10	<i>58,80</i>	k w
12,5	<i>72,30</i>	k w
14,2	<i>81,10</i>	w
16	<i>90,30</i>	w
260 x 140 x 6	<i>35,80</i>	k
6,3	<i>37,30</i>	k w
8	<i>46,50</i>	k w
10	<i>58,80</i>	k w
12,5	<i>68,30</i>	k w
14,2	<i>81,10</i>	w
16	<i>90,30</i>	w
260 x 180 x 6	<i>39,60</i>	k
6,3	<i>41,90</i>	k w
8	<i>52,70</i>	k w
10	<i>65,10</i>	k w
12,5	<i>80,10</i>	k w
14,2	<i>90,10</i>	k w
16	<i>100,00</i>	w
300 x 100 x 5	<i>30,10</i>	k
6	<i>35,80</i>	k
8	<i>46,50</i>	k
10	<i>57,00</i>	k
12,5	<i>68,30</i>	k
300 x 150 x 8	<i>52,80</i>	k
10	<i>65,10</i>	k w
12,5	<i>82,09</i>	k w

Abmessung	kg/m	Kategorie
300 x 200 x 6	<i>45,20</i>	k
6,3	<i>47,10</i>	k
8	<i>60,30</i>	k w
10	<i>74,50</i>	k w
12,5	<i>91,90</i>	k w
16	<i>115,00</i>	w
350 x 250 x 8	<i>72,80</i>	k w
10	<i>90,20</i>	k w
12,5	<i>112,00</i>	k w
16	<i>141,00</i>	w
400 x 100 x 8	<i>60,30</i>	w
400 x 200 x 8	<i>71,60</i>	k w
10	<i>88,40</i>	k w
12,5	<i>108,00</i>	k w
16	<i>141,00</i>	w
400 x 300 x 8	<i>85,40</i>	k w
10	<i>106,00</i>	k w
12,5	<i>131,00</i>	w
14,2	<i>148,00</i>	w
16	<i>166,00</i>	w
450 x 250 x 10	<i>106,00</i>	w
12,5	<i>131,00</i>	w
16	<i>166,00</i>	w
500 x 300 x 10	<i>122,00</i>	k w
12,5	<i>151,00</i>	k w
16	<i>191,00</i>	w
20	<i>235,00</i>	w

Kat. K = kaltgewalzt EN 10219-1+2, S235 JRH/JOH bzw. S355 JOH/J2H

Kat. W = warmgewalzt EN 10210-1+2, S355 J2H



RP-Profile

RP-Standard-Profile

LINE 30

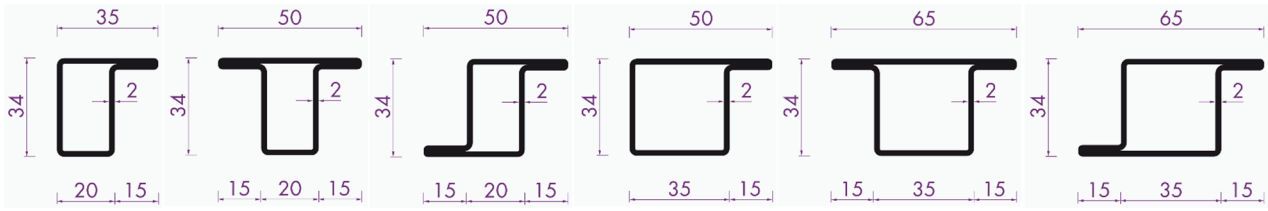

RP 144

RP 143

RP 169

RP 106

RP 105

RP 139

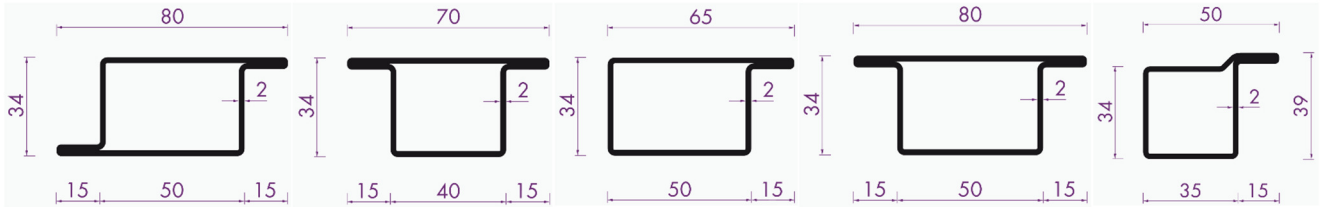

RP 111

RP 1050

RP 1191

RP 103

RP 133

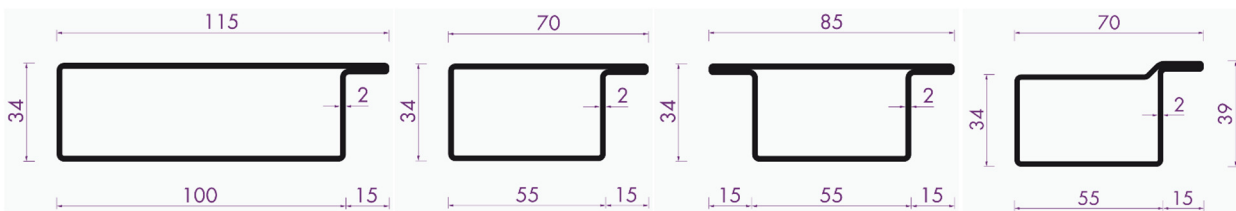

RP 1092

RP 104

RP 150

RP 114

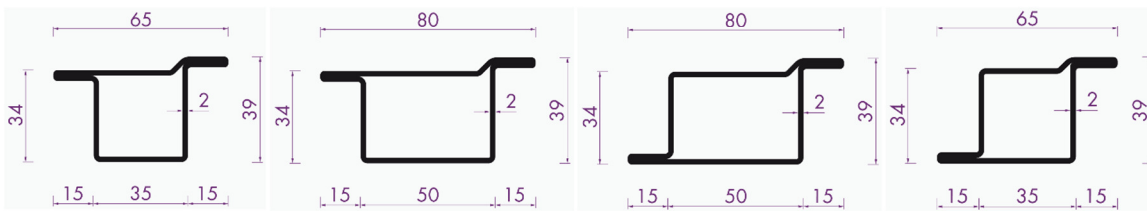

RP 140

RP 113

RP 112

RP 138

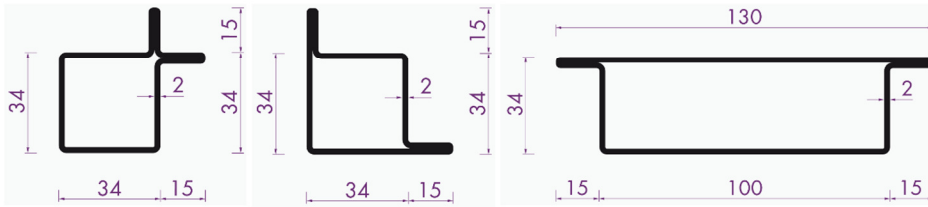

RP 141

RP 142

RP 1266

LINE 40

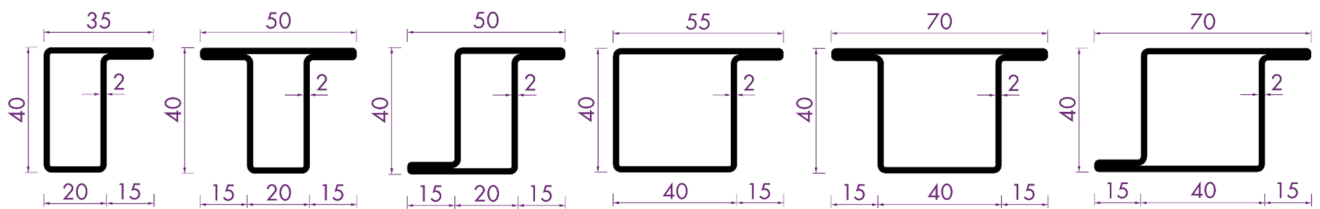

RP 1114

RP 185

RP 1163

RP 1008

RP 152

RP 1162

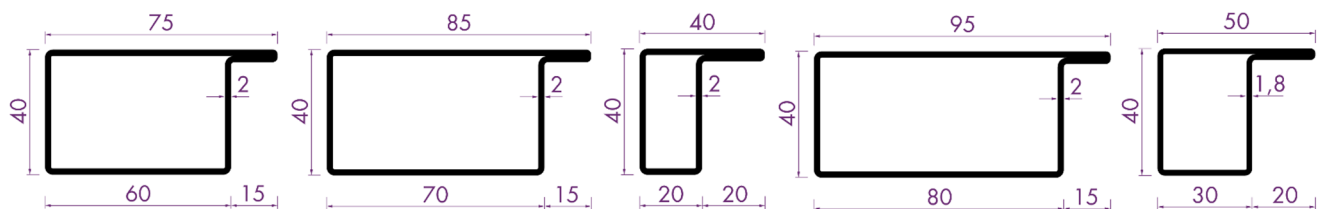

RP 1049

RP 1087

RP 1692

RP 116

RP 1672

LINE 40

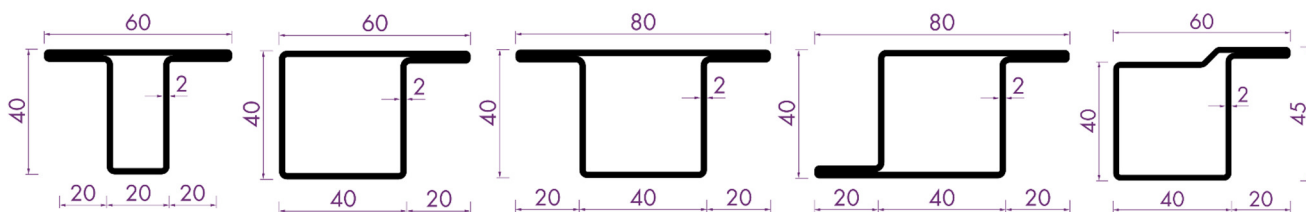

RP 1693

RP 1683

RP 1684

RP 1685

RP 1640

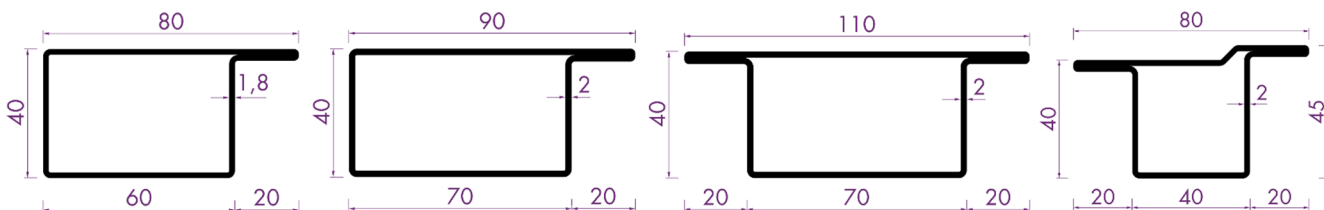

RP 1673

RP 1679

RP 1690

RP 1639

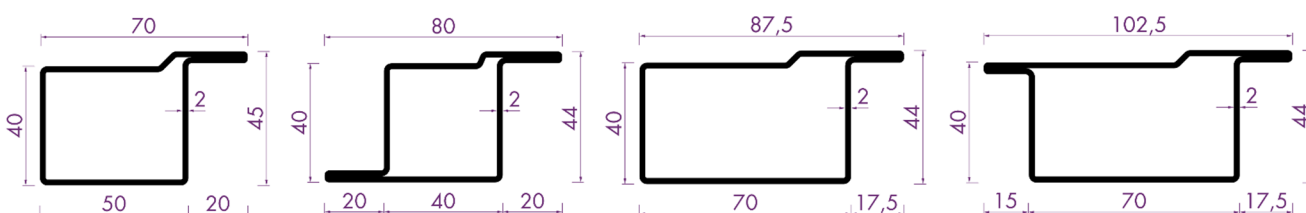

RP 1628

RP 1680

RP 1348

RP 1093

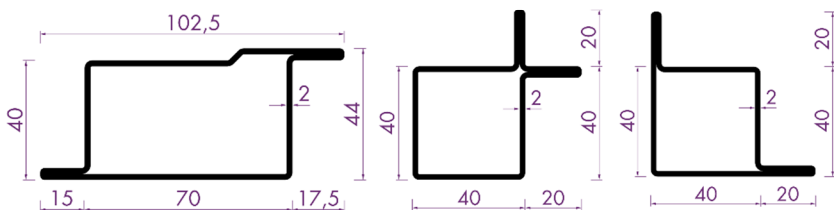

RP 1094

RP 1695

RP 1698

LINE 50

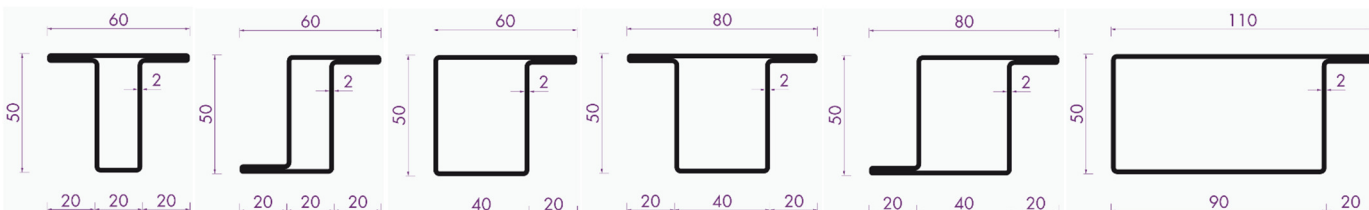

RP 193

RP 195

RP 1072

RP 1070

RP 1071

RP 1688

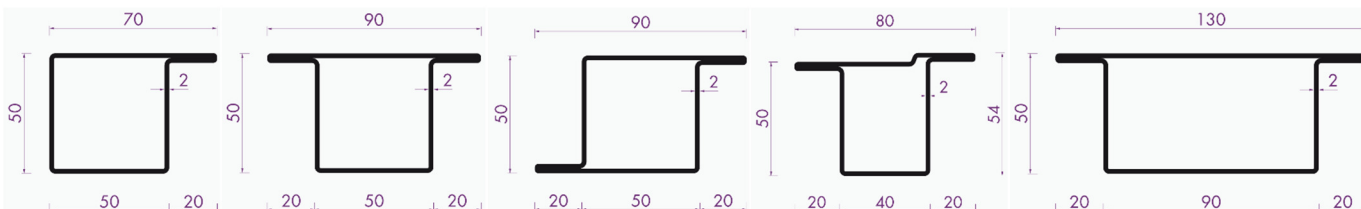

RP 1810

RP 1811

RP 1812

RP 168;

RP 1689

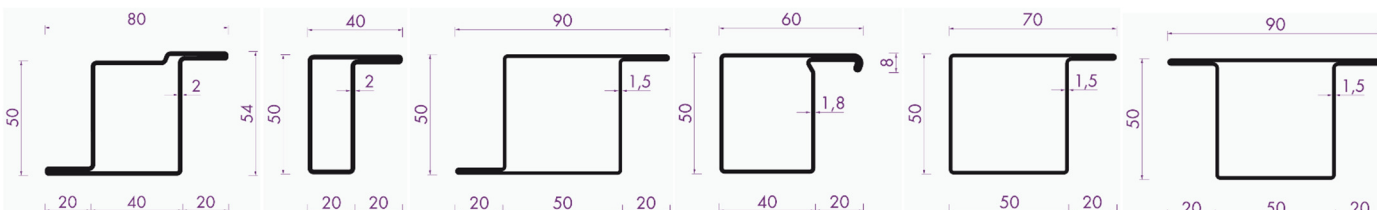

RP 1681

RP 197

RP 1835

RP 1783

RP 1833

RP 1834

RP-Profile

LINE 60

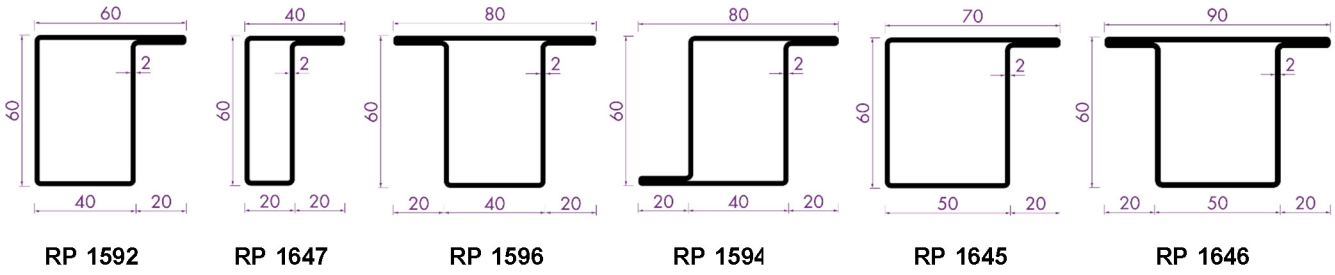

LINE 80

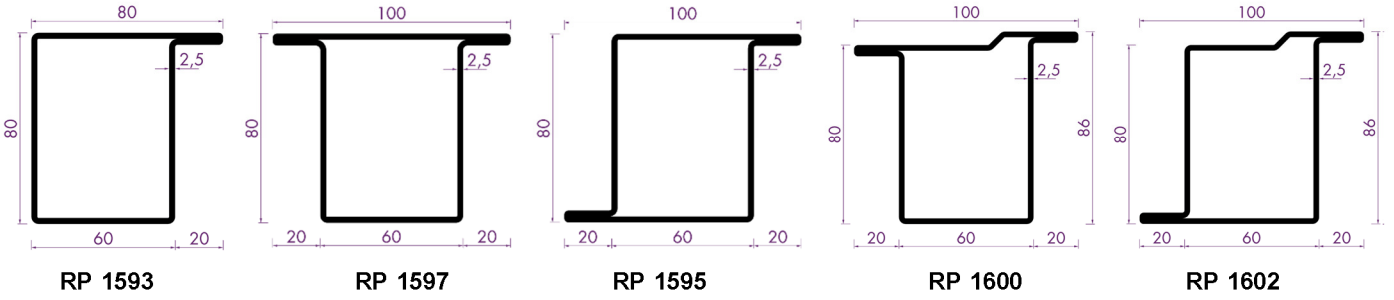

LINE S

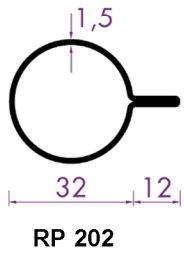

Glashalteleisten Stahl

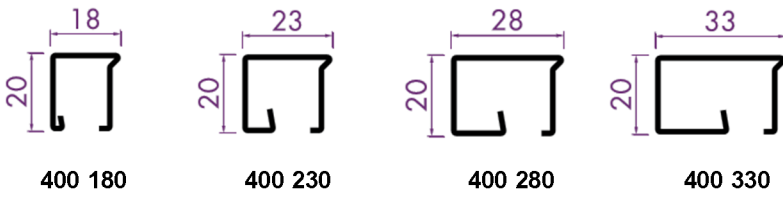

Dichtungen

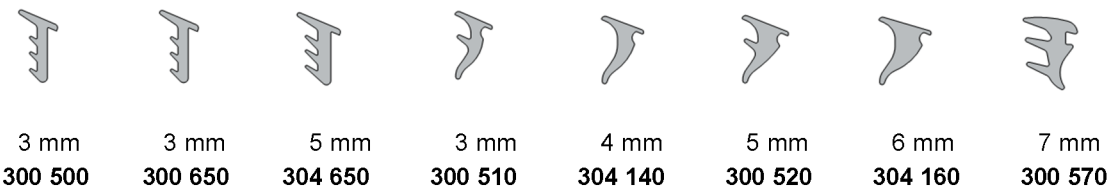



Spezialprofile

U-Bordwandprofile

U-Baustahl

Spezialprofile

Spezialprofile

Kipperleistenprofile, S235 JR

Handelslänge ca. 6 m



Abmessung in mm

45 x 30 x 62 x 4

Scheuerleistenprofile, S235 JR

Handelslänge ca. 6 m



Abmessung in mm

70 x 50 x 35 x 10 x 2,5

Radreifenprofile, S235 JR

Handelslänge ca. 6 m



Abmessung in mm

50 x 20 x 16 x 3,3

U-Bordwandprofile S235 JR

Handelslänge ca. 6 m

▲ sendzimir verzinkt

Abmessung in mm	Wandstärke in mm
	1,5
20 x 20	▲
21 x 21	▲
23 x 23	▲
25 x 25	▲
28 x 28	▲
30 x 30	▲

U-Baustahl, DIN EN 10055, S235 JR

Handelslänge ca. 6 m

Abmessung in mm	3	4	5	6
40 x 40	●			
46 x 45	●			
50 x 40		●		
54 x 45		●		
62 x 45		●		
70 x 50		●		
80 x 50			●	
90 x 50			●	
100 x 50			●	
120 x 60				●
140 x 60				●
160 x 65				●

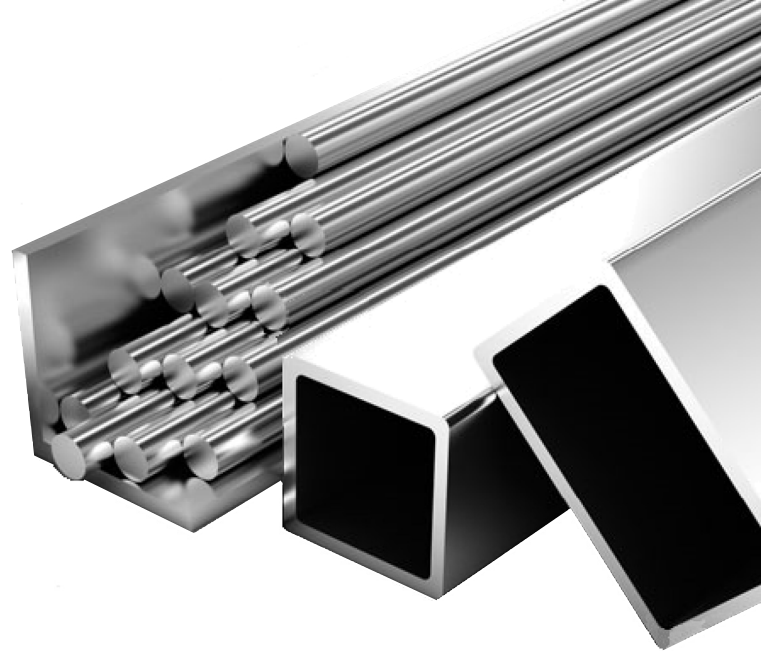

nichtrostende Stähle

Stabstahl

Konstruktionsrohre

Leitungsrohre

Bleche

Profilrohre

geschliffen Korn 240

Edelstahlflach, Wst. 1.4301

- vom Band geschnitten, HL ca. 4 m
- ◆ allseits geschliffen Korn 240, HL ca. 4 m

Abmessung in mm	3	4	5	6	8	10	12	15
20		●	●	●	●	●		
25		●	●	●	●	●		
30	●	●	● ◆	● ◆	● ◆	●		
35			●					
40		●	● ◆	● ◆	● ◆	● ◆	●	●
50			● ◆	● ◆	● ◆	● ◆	●	●
60			● ◆	● ◆	● ◆	● ◆	●	●
80			●		●	●		
100			●		●	●		
120						●		

Edelstahlrund, Wst. 1.4301

- blank gezogen, DIN 671 h9, HL ca. 3 m
- ◆ geschliffen Korn 240, HL ca. 6 m

Abmessung in mm	blank	geschliffen
3	●	
4	●	
5	●	
6	●	
8	●	
10	●	◆
12	●	◆
14	●	
15	●	
16	●	
18	●	
20	●	
25	●	
30	●	
35	●	
40	●	

Edelstahlvierkant, Wst. 1.4301

- blank gezogen, DIN 176, HL ca. 3 m

Abmessung in mm	blank	
10	●	
12	●	
20	●	

Edelstahlrohre, EN 10217-7

geschw. ungegl., Handelslängen ca. 6 m

- Wst. 1.4301
- Wst. 1.4571/1.4404

Durchmesser in mm	Wandstärke in mm					
	2,0	2,3	2,6	3,0	3,2	3,6
17,2		●				
21,3	● ■		● ■			
26,9	● ■		● ■			
33,7	● ■				● ■	
42,4	● ■				● ■	
48,3	● ■				● ■	
60,3	● ■					● ■
76,1	● ■			● ■		
88,9	● ■			● ■		
101,6	● ■			● ■		
108,0	● ■			● ■		
114,3	● ■			■		
139,7	● ■			● ■		
154,0	● ■					
168,3	■			●		
204,0	● ■					
219,1	● ■			■		
254,0	■					

Konstruktionsrohre, Wst. 1.4301

geschw. ungegl., Handelslängen ca. 6 m

- unbehandelt
- ◆ geschliffen Korn 240

Durchmesser in mm	Wandstärke in mm					
	1,5	2,0	2,3	2,5	3,0	3,65
20,0		● ◆				
21,3		● ◆		●		
25,0		● ◆				
26,9		● ◆		●		
30,0		● ◆				
33,7		● ◆			●	
42,4		● ◆			● ◆	
48,3		● ◆			● ◆	
60,3	●	● ◆				●
76,1		● ◆			●	
88,9		● ◆			●	
101,6		● ◆				
114,3		● ◆				
139,7					●	
168,3		●			●	
204,0		●				

Edelstahlprofilrohre Wst. 1.4301

- Wst. 1.4301, unbehandelt
- ◆ Wst. 1.4301, geschliffen K 240
- Wst. 1.4571/1.4404, unbehandelt

Abmessung in mm	Wandstärke in mm					
	1,5	2	2,5	3	4	5
15 x 15	●					
20 x 20		● ◆				
25 x 25		●				
30 x 30		● ◆				
35 x 35		●				
40 x 40		● ◆ ■		●		
50 x 50		● ◆ ■		● ■		
60 x 60		● ◆		●		
70 x 70				●		
80 x 80		●		●	●	
100 x 100		●		●		

Abmessung in mm	Wandstärke in mm					
	1,5	2	2,5	3	4	5
30 x 15		●				
30 x 20		●				
40 x 20		● ◆				
40 x 30		●				
50 x 30		● ◆				
60 x 30		●				
60 x 40		● ◆				
80 x 40		●		●		
80 x 60		◆		●		
100 x 50		●		●		
100 x 60				●		

Edelstahlwinkel Wst. 1.4301

- unbehandelt, Handelslänge ca. 6 m

Abmessung in mm	Wandstärke in mm					
	3	4	5	6	8	10
20 x 20	●					
25 x 25	●					
30 x 30	●					
35 x 35		●				
40 x 40		●				
50 x 50			●			
60 x 60				●		
80 x 80					●	
100 x 100						●

Edelstahlbleche

kaltgewalzt III C bzw. warmgewalzt C2

- Wst. 1.4301 roh
- ★ Wst. 1.4301 einseitig mit Laserfolie
- ▲ Wst. 1.4301 beidseitig mit Laserfolie
- ◆ Wst. 1.4301 einseitig geschliffen K 240 mit Laserfolie
- Wst. 1.4571/1.4404, unbehandelt

Blechstärke in mm	Blechformat in mm		
	1000 x 2000	1250 x 2500	1500 x 3000
1,00	●	● ★ ◆	● ■ ★ ◆
1,50	● ▲	● ★ ◆ ▲	● ■ ★ ◆ ▲
2,00	● ▲	● ★ ◆ ▲	● ■ ★ ◆ ▲
3,00	●	● ★ ◆	● ■ ★ ◆
4,00	●	●	● ■ ★ ◆
5,00	●	●	● ★ ◆
6,00	●	●	● ■
8,00	●	●	● ■
10,00	●		●
12,00	●		●
15,00			●

Edelstahl-Tränenbleche Wst. 1.4301

Ausführung Mandorla

Blechstärke in mm	Blechformat in mm		
	1000 x 2000	1250 x <u>3000</u>	1500 x 3000
3,00		●	
4,00			●
5,00			●



Aluminium

Profile

Rohre

Bleche

Aluminiumflach EN AW-6060

- AlMgSi0,5 Handelslänge ca. 6 m

Abmessung in mm	3	4	5	6	8	10
20	●	●	●			
30	●	●	●			
40	●	●	●			
50			●	●		
60			●	●		
80				●		

Aluminiumrund EN AW-6060

- AlMgSi0,5 Handelslänge ca. 6 m

Abmessung in mm		
Ø 6	●	
Ø 8	●	
Ø 10	●	
Ø 12	●	
Ø 15	●	

Aluminiumwinkel EN AW-6060

- AlMgSi0,5 Handelslänge ca. 6 m

Abmessung in mm	Wandstärke in mm			
	2	3	5	6
20 x 20	●			
30 x 30		●		
40 x 40		●		
50 x 50			●	
60 x 60			●	●

Aluminiumvierkantrohr EN AW-6060

- AlMgSi0,5 Handelslänge ca. 6 m

Abmessung in mm	Wandstärke in mm			
	1,5	2	2,5	3
20 x 20		●		
25 x 25		●		
30 x 30		●		
40 x 20		●		
40 x 40		●		
50 x 50		●		
60 x 40		●		
60 x 60		●		●
80 x 40		●		

Aluminiumrundrohr EN AW-6060

- AlMgSi0,5 Handelslänge ca. 6 m

Abmessung in mm	Wandstärke in mm
	2,0
20	●
25	●
30	●
40	●
50	●

Aluminiumbleche EN AW-5754 bzw. 5005

- AIMg3, H22
- ★ AIMg3, weich H111
- ◆ AIMg1 NQ, H24/34 einseitig foliert

Blechstärke in mm	Blechformat in mm		
	1000 x 2000	1250 x 2500	1500 x 3000
1,00	●	●	●
1,50	●	●	●
2,00	●	● ★	● ★ ◆
3,00	●	● ★	● ◆
4,00	●	●	●
5,00	●	●	●
6,00	★	★	★
8,00			★
10,00			★

Alu-Quintett-Bleche EN AW-5754

- AIMg3, H114

Blechstärke in mm	Blechformat in mm		
	1000 x 2000	1250 x 2500	1500 x 3000
2,5 / 4,0	●	●	●
3,5 / 5,0	●	●	●
5,0 / 6,5	●	●	●



Pressrosten

Press-Treppenstufen

Pressrosten

Pressrosten und -stufen

Feuerverzinkte Press-Treppenstufen

mit rutschhemmender Antrittskante und seitlichen Einfassungen aus Flacheisen mit Bohrungen zum Anbringen an die Treppenkonstruktion

Abmessung	Tragstab	Maschenweite
600 x 270	30 x 2	30 x 30
700 x 270	30 x 2	30 x 30
800 x 270	30 x 2	30 x 30
900 x 270	30 x 3	30 x 30
1000 x 270	30 x 3	30 x 30
1200 x 270	40 x 3	30 x 30

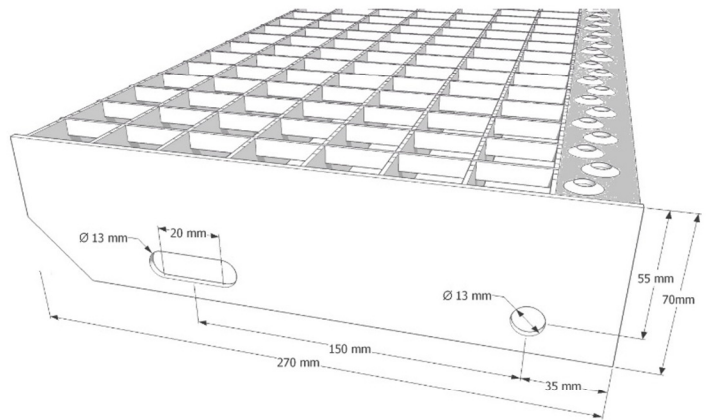

Feuerverzinkte Pressroste

Abmessung	Tragstab	Maschenweite
500 x 1000	30 x 2	30 x 30
600 x 1000	30 x 2	30 x 30
600 x 1200	30 x 2	30 x 30
750 x 1000	30 x 2	30 x 30
800 x 1000	30 x 2	30 x 30
1000 x 1000	30 x 2	30 x 30
1000 x 500	30 x 2	30 x 30
1200 x 600	30 x 2	30 x 30
1200 x 1000	30 x 2	30 x 30



Schweißpressroste

mit gedrillten Querstäben

Abmessung	Tragstab	Maschenweite	Oberfläche
6100 x 1000	30 x 2	30 x 30	roh
6100 x 1000	30 x 3	30 x 30	roh

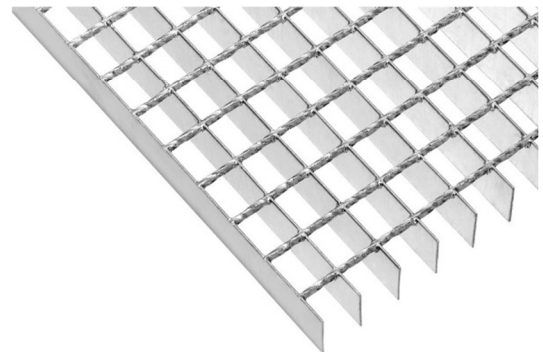

Pressrost-Antrittskante, gelocht

Antrittskante, roh *in Längen von 3000 mm*
 Antrittskante, verzinkt *in Längen von 3000 mm*

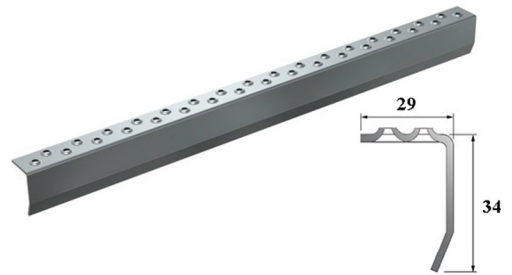

Leiterspinnenprofile *Variante 2*

Stahl StW 22 *35 x 30 x 2 mm, roh Länge 2000 mm*

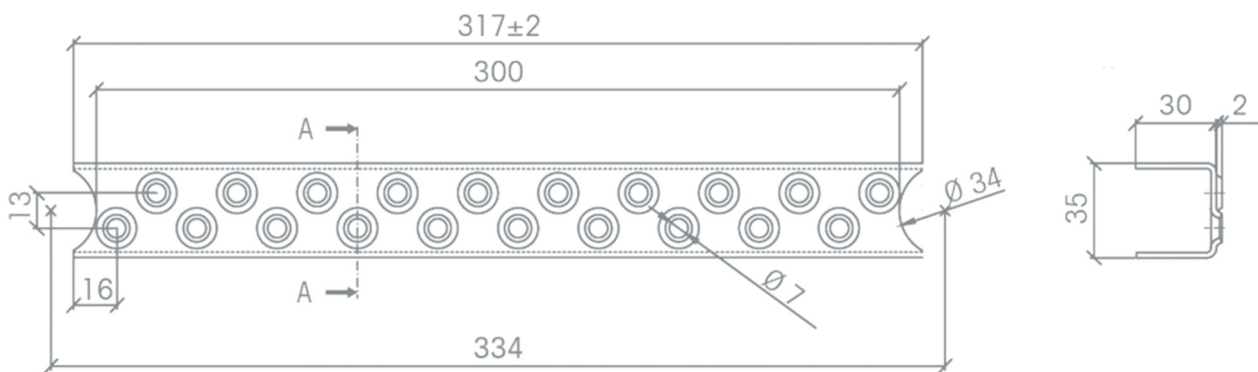

Pressrost - Befestigungssatz

Befestigungssatz bestehend aus Ober- und Unterteil, Schraube



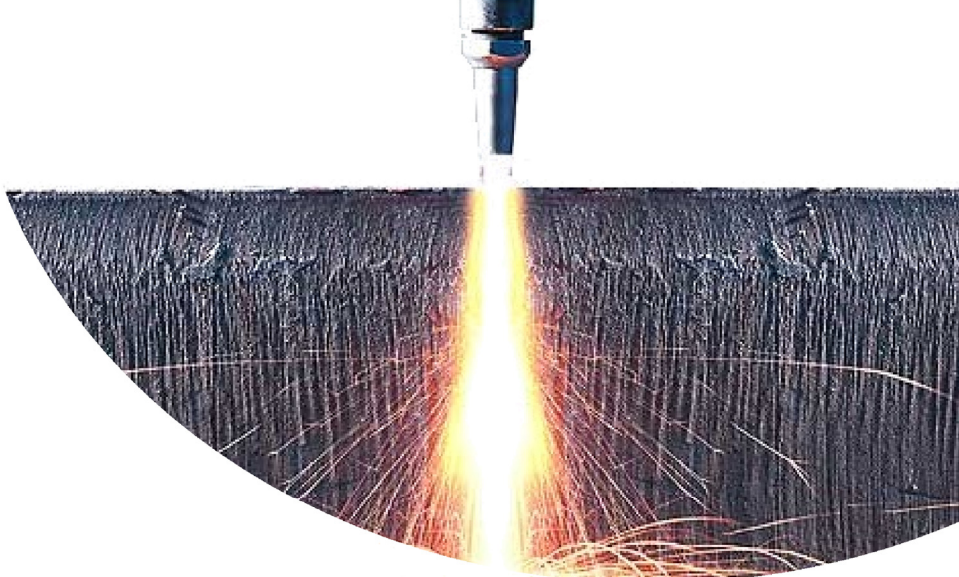

Anarbeitung

Brennzuschnitte

Plasma- und Autogenschneide

nach ISO 9013-II B, normaleben, von Brennschlacke befreit,
sonst unbehandelt



Bearbeitungsfläche 3000 x 12000 x max. 130 mm

1 Plasmaschneidkopf
2 Autogenschneidköpfe

S235JR, S355J2 und S355MC von 3 - 20 mm
S235JR, S355J2 und S355MC von 25 - 130 mm
(S355MC Verfügbarkeit auf Anfrage)

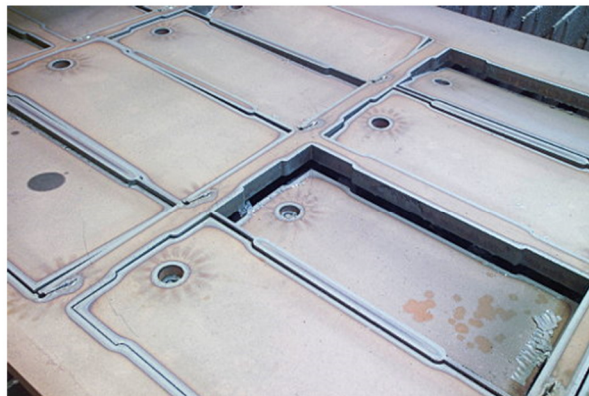
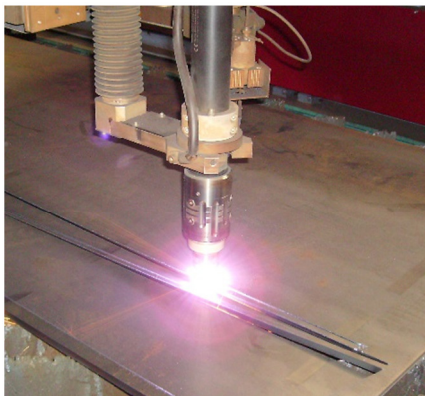

Datenaustausch :

DXF, DWG (ggf. bemaßte Zeichnungen)

Als einer der bedeutendsten Lagerhändler haben wir es uns zur Aufgabe gemacht, dem Stahlverarbeiter eine hohe und schnelle Verfügbarkeit der von ihm benötigten Stahlprodukte zu gewährleisten.

Unsere Lieferungen von Lagermaterial erfolgen, mit Ausnahme von angearbeitetem Material, auf Wunsch binnen 24 Stunden.



Stand: Februar 2016

Für etwaige Fehler oder Irrtümer schließen wir jede Haftung aus.



Frieling



SANITÄR · HEIZUNG · STAHL

Fritz Frieling GmbH
Gewerbering 5+28
49393 Lohne

Tel. 04442 - 944-0
Fax 04442 - 944-219
E-Mail: stahl@frieling24.de

Langenweg 16-18
26125 Oldenburg

Tel. 0441 - 93 330-0
Fax 0441 - 93 330-18
E-Mail: oldenburg@frieling24.de